

JK46A

4x 6" ACTIVE
FULL RANGE COLUMN
SPEAKER SYSTEM

Joker



HIGHLIGHTS

The JK46A is an active column system composed by 4x 6" neodymium woofers with carbon fiber cone and 1x 1.75" voice coil neodymium compression driver coupled to a 50° to 100° x 55° asymmetrical dispersion horn.

The JK46A design concept allows a true FULL RANGE sound reproduction in a very light and compact enclosure.

The Class D amplifier delivers 700 W (1400 W peak) and it is controlled by a DSP.

The DSP provides all necessary signal processing (crossover, EQs, delay, limiters, input overload) as well as several useful presets to adjust JK46A to different requirements.

The amplifier's SMPS (switch mode power supply with around 90% of efficiency) allows to deliver maximum power with minimum consumption in an extremely low weight size.

The amplifier's rear connections and control panel has a graphic LCD screen to display the different settings, presets, volume control and adjustments done by the user. A capacitive keyboard guarantees the reliability of the system even under humidity and extreme weather conditions.

Connectors are placed on a 45° plane to effectively protect them from rain or moisture.

The on-screen output power display and limiter led help to easily monitor the system.

Several accessories allow easy flying. A 35 mm socket for mounting the loudspeaker on a speaker stand is provided in the bottom of the cabinet.

The cabinet is made in birch plywood with internal metal angles for rigging. It is painted with Polyurea® to offer the maximum reliability and strength for touring as well as for top demanding applications.

Stylized design and low weight ready for everything!

4x 6" woofers and a 1.75" long throw asymmetrical horn make JK46A a truly multipurpose FULL RANGE system with a wide frequency response and great sound quality.

JK46A

4x 6" ACTIVE FULL RANGE COLUMN SPEAKER SYSTEM

Joker



CARBON FIBER CONE



LIGHT NEODYMIUM COMPONENTS



ASYMMETRICAL HORN



MULTIPLE PRESETS AVAILABLE



WEATHER RESISTANT



ACCESSORIES FOR EASY INSTALLATIONS



HIGH RESISTANT POLYUREA® PAINT

TECHNICAL FEATURES

Amplifier (Class D Bi-amplified)	600 + 100 W (program) 1200 + 200 W (peak)
Input sensitivity	8 dBu – 1.94 V
Input Impedance	20 kΩ Balanced
Maximum input level	20 dBu
Mains	Universal Switching Power Supply 85-265 V/45-65 Hz
Average current draw	0.7 A (Heavy duty musical program)
SPL (1 m)	125 dB continuous, 128 dB peak
Built-in DSP	48 bit (including several factory presets)
AD/DA converters	24 bit – 48 kHz
Standby mode consumption	< 5 W
Adjustable Delay line	118 ms / 40 m
Crossover frequency	1k4 Hz
Frequency response (-10 dB)	50 Hz – 19 kHz
Components LF–MF HF	4x 6" Neodymium woofers with carbon fiber cone (1.5" voice coil) 1.75" PETP diaphragm neodymium driver
Directivity (HxV)	50° to 100° x 55°
Directivity factor (Q)	12.6
Directivity index (DI)	11 dB
Finish	Multilayer plywood with high resistant black Polyurea® coating
Grille	1.5 mm steel with foam
Rigging	M8 points
Connectors	1x XLR input 1x XLR link 1x AC powercon input
Dimensions (HxWxD)	1052 x 250 x 260 mm
Weight	18.5 kg



JK46A

4x 6" ACTIVE
FULL RANGE COLUMN
SPEAKER SYSTEM

Joker



HORIZONTAL COVERAGE

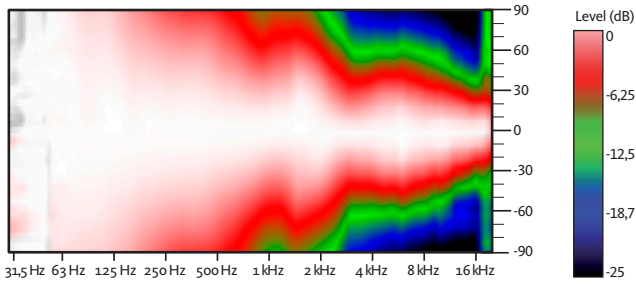

VERTICAL COVERAGE

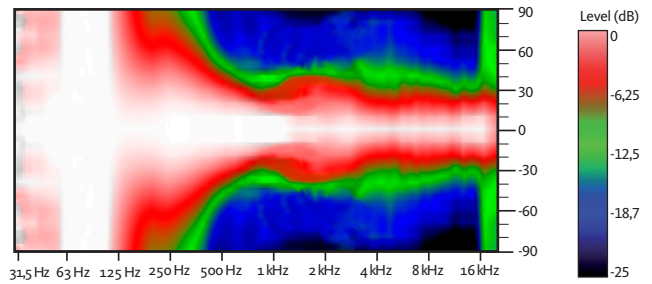

FREQUENCY RESPONSE 1W/1m (FLAT PRESET)

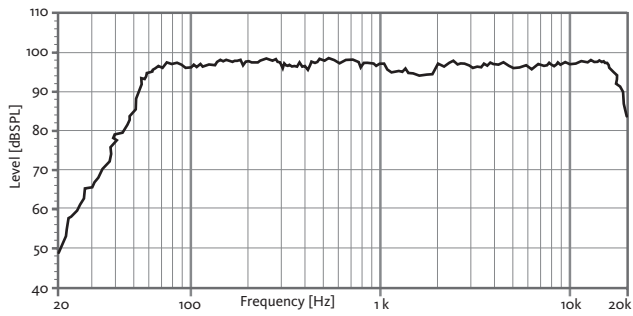

DIRECTIVITY INDEX (DI)

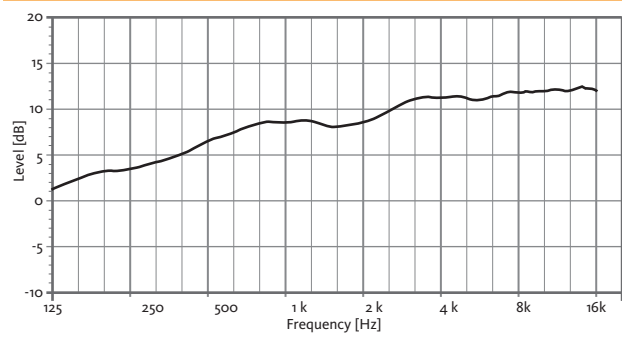

HORIZONTAL BEAMWIDTH (-6dB point)

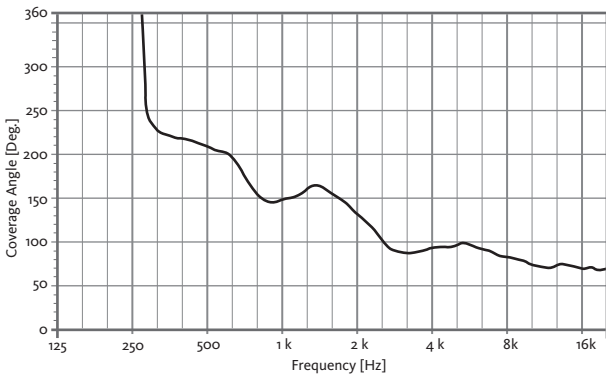

CAD DRAWING SCHEME

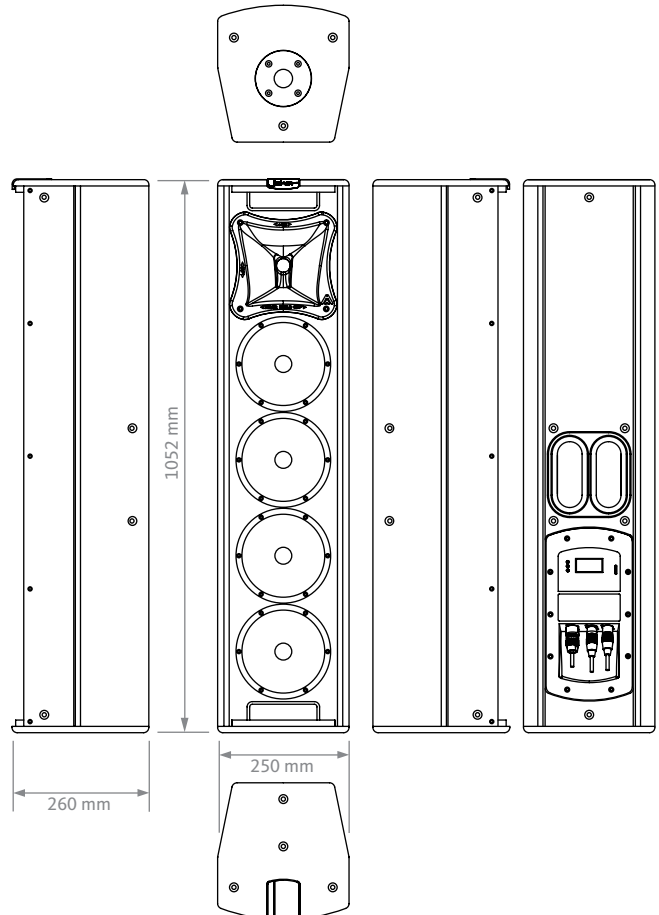

VERTICAL BEAMWIDTH (-6dB point)

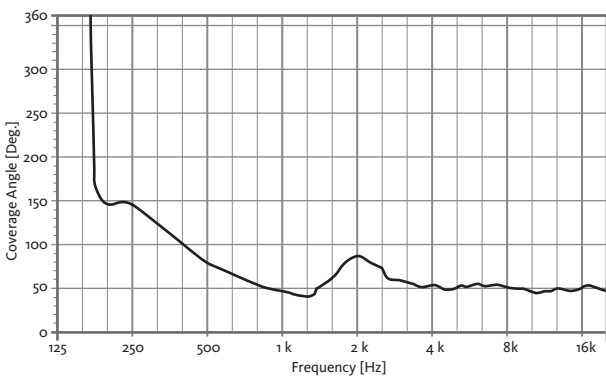

JK46A

4x 6" ACTIVE
FULL RANGE COLUMN
SPEAKER SYSTEM

Joker



ASYMMETRICAL HORN

Good coverage of audiences often is a conflicting combination of:

- *wide coverage for the closest audience (short throw)
- *narrow coverage for distant areas (long throw)

The asymmetrical dispersion horn coverage varies from "short throw" to "long throw" along the vertical axis (keeping a constant vertical directivity).

Vertical-Positioned JK46A (Flown and aiming to the audience)

We need wide coverage (100°) for the closest listeners and narrow coverage for the distant audience.

Directivity feature of (50° to 100°(H), 55°(V)) can be seen as if the horn itself had "two" horizontal directivities (audience coverage), which depend on the distance.

For short distances the horn should be used with its "wide" dispersion (100°).

For long distances the horn should be used with its "narrow" dispersion (50°).

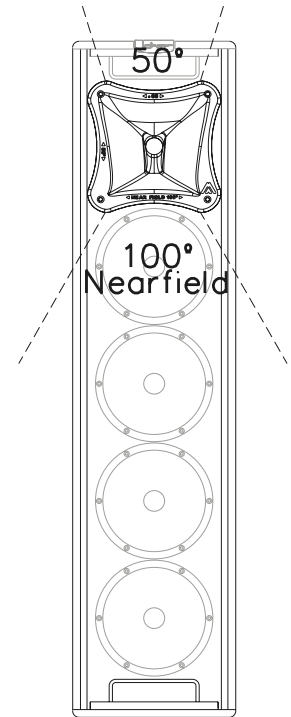
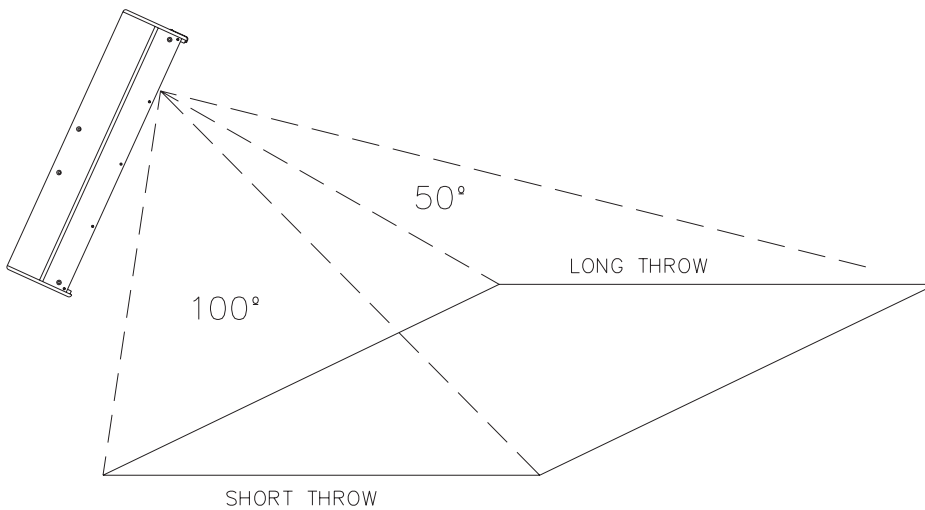

ACCESSORIES

VERTICAL COLUMN-MOUNT HR-26 + SC-15

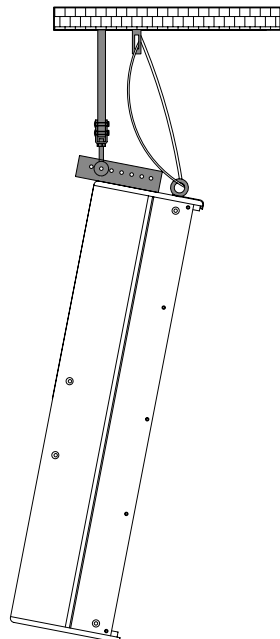
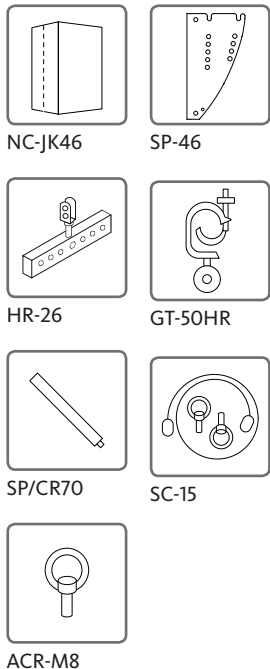

VERTICAL TRUSS-MOUNT HR-26 + GT-50HR + SC-15

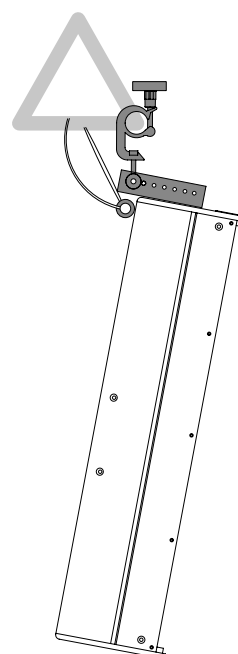

VERTICAL WALL-MOUNT SP-46

